

CR Scotseal hubcap family



Hubcaps for P.S.I. applications

- Hubcaps compatible with Meritor® Tire Inflation System (MTIS™) by P.S.I.
- Fusion-bonded window
- Oil bath and grease-packed designs
- Available in black or gray



Hubcaps for oil bath applications

- Lightweight nylon composite material
- Embedded solid aluminum ring, distributes an even, leak proof load against the hub
- Increased impact resistant
- Leak-proof window is fusion-bonded to body
- Compatible with all popular oils including the latest synthetics



Hubcaps for grease packed applications

- Designed for semi-fluid grease applications
- “Umbrella” valve vent seals out contaminations yet vents internal pressure as low as 2 psi when covered by 1/4” of grease
- Addition of a splash plate to the hubcap design helps protect against the harsh conditions created by road spray, power washers and flooded docks

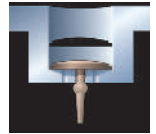

**LIGHTER THAN STEEL.
TOUGHER THAN ALUMINUM.**



Lexan® hubcaps

- Lightweight, molded design using GE's Lexan handles harsh conditions
- Sealed models for grease-packed systems
- Oil and grease pro-par applications



Stamped Steel hubcaps

- Zinc-plated
- Protected with weather-resistant armor
- Resists rust and rough wear



View detailed technical and product videos at www.skfpartsinfo.tv



Follow us on Twitter @skfpartsinfo to stay on top of all the latest technical and product information.

Trouble-Free (TF) hubcap for oil bath applications

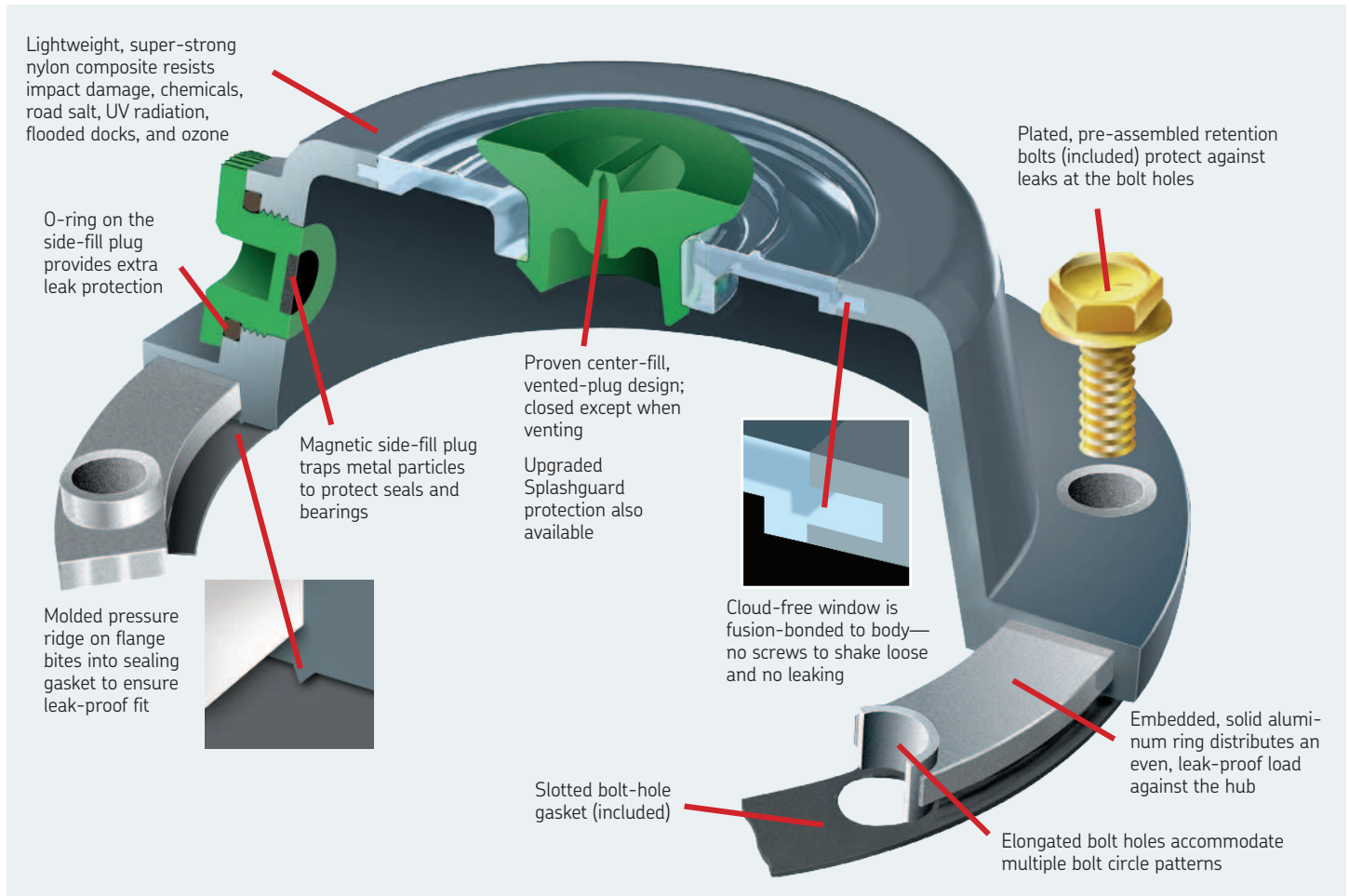

Splashguard center-fill plug Upgraded vent system and protection

SKF Splashguard technology is a contaminant exclusion system that provides extra splash protection. The Splashguard protects the wheel end from water ingestion caused by high pressure washer spray and submersion.

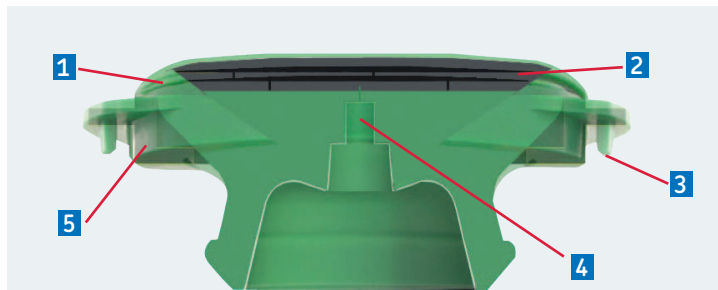

- 1 Hard shell** - resists power washing, road debris
- 2 Multiple labyrinth** - prevents contaminants from reaching wheel end
- 3 Side tabs** - allow for easy removal
- 4 Pressure sensitive vent** - vent closed unless releasing pressure eliminates entry path for contaminants
- 5 Extended surface** - adds coverage between window plug for better sealing



Splashguard center plugs are available in green and black 4 packs	Standard center plug	Splashguard center plug
Green	450434-4	450439-4
Black	453807-4	450438-4
Display (6 sets each)		454210
Display (12 sets green)		454215
Display (12 sets black)		454216

Hubcap barrel program



Available in single box, case quantities and barrel quantities

Base part number	Add suffix for bulk qty of -24	Add suffix for barrel quantity	Barrel quantity
1343	-C24	B-100	100
1399		B-75	75
1612	-C24	B-100	100
1643	-C24	B-100	100
1644	-C24	B-100	100
1696		B-75	75
1743		B-100	100

*All hubcaps come with gaskets and bolts

Hubcap interchange reference chart

SKF TF/Nylon composite			Stemco				National	Dual Dynamics		SKF	
Oil	Grease	Application	Oil	Oil	Sentinel Oil	Sentinel Grease	Oil	Oil	Grease	Steel	
1282 ¹	1284 ¹	Pro-Par Trailer		343-4975		348-4075	349-4075	HU-075A	276-P	275-G	
1600		Trailer/Hubo	347-4009								
1608 ²		Steer	340-4065	343-4065				HU-065A			
1612 ²	1326 ²	Steer	340-4024	343-4024	350-4024			HU-024A	302-P	301-G	1711
1613 ²		Steer	340-4249	343-4249	350-4249			HU-149A			1703
1623		Trailer	340-4066	343-4066				HU-066A			1723
1627		Trailer	340-4002	343-4002							1727
1627		Steer	340-4019	343-4019				HU-019A			
1630 ²		Trailer	340-4014	343-4014						202-G	
1642		Trailer	340-4013	343-4013		348-4013	349-4013	HU-013A	282-P		1742
1643	1343	Trailer	340-4009	343-4009		348-4009	349-4009	HU-009A	203-P	283-G	1743
1643	1343	Trailer	340-4046	343-4046				HU-046A	303-P	304-G	
1644 ²	1343	Trailer/Steer	340-4009	343-4009		348-4009	349-4009				1743
	1343W	Trailer					342-4009				
1665		Trailer	340-4042	343-4042				HU-042A			1765
1669 ²		Steer	340-4025	343-4025	350-4025			HU-036A			
1670 ²		Steer	340-4034	343-4034	350-4034			HU-034A			1770
1681		Trailer	340-4029	343-4029				HU-028A			
1691 ²		Steer	340-4098	343-4098							1790
1696	1399	Trailer	340-4195	343-4195		348-4195	349-4195		257-P	255-G	1796
	1399W	Trailer					342-4195				
1698		Trailer	340-4059	343-4059							1798
1698		Trailer	340-4080	343-4080							
1943 ³	1443 ³	Trailer		343-4370			340-4350		207-P	401-G	
1945 ⁴	1443 ³	Trailer		343-4370			340-4350		207-P	401-G	
1995 ⁴	1499 ³	Trailer		343-4372			340-4352		260-P	456-G	
1996 ³	1499 ³	Trailer		343-4372			340-4352		260-P	456-G	

1-Lexan design 2-Black design 3-Designed for PSI system, Gray 4-Designed for PSI system, Black

Trouble-Free (TF) hubcaps

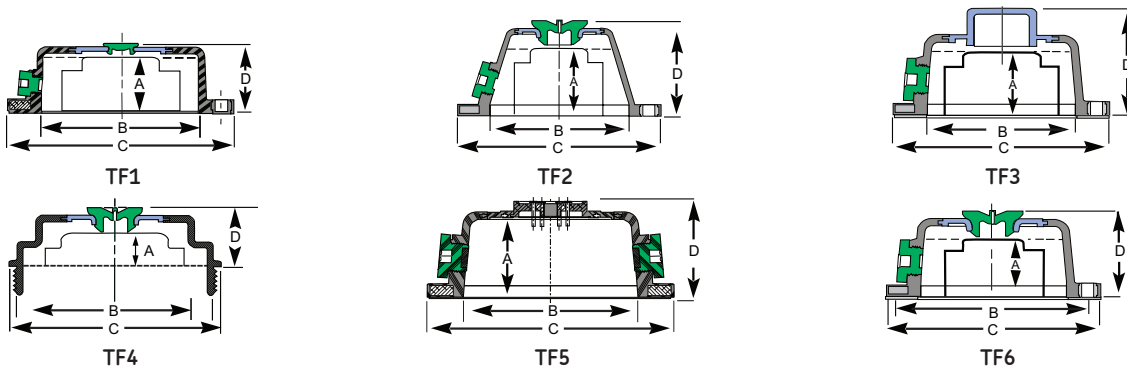

Bolt holes	Hole size	Bolt circle	Max. axle Ext. (A)	Hubcap size			Type	Hubcap kit	Gasket ⁶	Std. Plug ⁶	Splashguard plug ⁶	Side fill ⁶
				I.D. (B)	O.D. (C)	Height (D)						
3	0.416	5.250	2.125	4.132	6.000	2.632	TF6	1627	453912-8	450434-4	450439-4	453770-4
4	0.349	3.625	1.808	2.400	4.313	2.024	TF6	1608 ²	453868-8	453879-4	-	453811-4
4	0.349	5.000	1.375	4.060	5.615	1.880	TF6	1681	453915-8	450434-4	450439-4	453770
5	0.349	5.500	1.730	4.440	6.250	2.469	TF6	1642	453818-4	450434-4	450439-4	453770-4
6	0.286	6.625	1.775	5.526	7.344	2.564	TF6	1670 ²	453825-8	450434-4	450439-4	453770-4
6	0.349	5.500-5.562	1.990	4.432	6.250	3.082	TF3	1600 ⁴	453795-8	-	-	453770-4
6	0.349	4.500	1.880	3.500	5.250	2.609	TF6	1612 ^{2,5}	453869-8	453807-4	450438-4	453811-4
6	0.349	5.500-5.562	1.586	4.385	6.250	1.643	TF1	1613 ²	453795-8	453879-4	-	453942-4
6	0.349	5.125-5.250	2.125	4.132	6.000	2.632	TF6	1623	453909-8	450434-4	450439-4	453770-4
6	0.349	5.500-5.562	2.220	4.290	6.250	2.727	TF2	1630 ²	453795-8	453807-4	450438-4	453811-4
6	0.349	5.500-5.562	1.730	4.440	6.250	2.469	TF6	1643 ⁵	453795-8	450434-4	450439-4	453770-4
6	0.349	5.500-5.562	1.730	4.440	6.250	2.469	TF6	1644 ^{2,5}	453795-8	453807-4	450438-4	453811-4
6	0.349	5.125-5.250	1.400	4.132	6.000	1.905	TF6	1665	453909-8	450434-4	450439-4	453770-4
6	0.349	5.875	1.323	4.715	6.580	1.600	TF6	1669 ²	453918-8	453813-4	-	453819-4
6	0.349	5.500-5.562	1.120	4.257	6.250	1.397	TF1	1691 ²	453795-8	453879-4	-	453942-4
6	0.349	6.750	2.887	5.625	7.500	3.688	TF6	1696 ⁵	450799-8	450434-4	450439-4	453770
6	0.349	5.500-5.562	1.703	4.420	6.250	2.441	TF5	1943 ³	453795-8	-	-	453770(2)
6	0.349	5.500-5.562	1.703	4.420	6.250	2.441	TF5	1945 ^{2,3}	453795-8	-	-	453770(2)
6	0.349	6.750	2.805	5.627	7.500	3.650	TF5	1996 ³	453795-8	-	-	453770(2)
6	0.349	6.750	2.805	5.627	7.500	3.650	TF5	1995 ^{2,3}	453795-8	-	-	453770(2)
6	0.416	6.000	2.000	5.000	6.750	2.507	TF6	1698	453906-8	450434-4	450439-4	453770
6.250 x 8 O.D.		Threaded	1.886	6.060	6.465	1.750	TF4	1282 ¹	454051-4	450434-4	450439-4	-

1-Lexan design 2-Black design 3-Designed for PSI system 4-Hubodometer mount design 5-Available as Splashguard caps (i.e. 1612-SG) 6-Order in multi-pack part nos.

Tamper-proof (TP) hubcaps

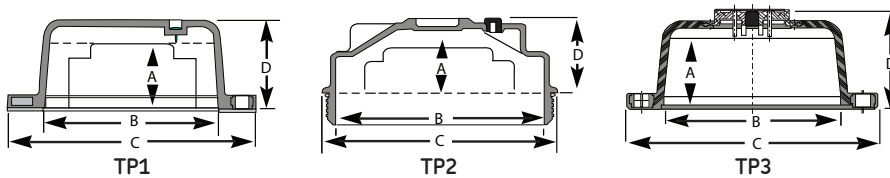

Bolt holes	Hole size	Bolt circle	Max. axle Ext. (A)	Hubcap size			Type	SKF number	
				I.D. (B)	O.D. (C)	Height (D)		Hubcap kit	Replacement gasket ⁴
6	0.349	4.500	1.878	3.480	5.250	2.370	TP1	1326	453869-8
6	0.349	5.500	1.703	4.440	6.250	2.161	TP1	1327	453795-8
6	0.349	5.500-5.562	1.703	4.420	6.250	2.161	TP1	1343	453795-8
6	0.349	5.500-5.562	1.703	4.420	6.250	2.431	TP3	1443 ³	453795-8
6	0.349	6.750	2.805	5.627	7.500	3.370	TP1	1396	450799-8
6	0.349	6.750	2.805	5.627	7.500	3.370	TP1	1399	450799-8
6	0.349	6.750	2.805	5.627	7.500	3.640	TP3	1499 ³	450799-8
6.250 x 8 O.D.		Threaded	1.500	6.060	6.875	1.875	TP2	1284 ^{4,2}	454051-4

1-Lexan design 2-Black design 3-Designed for PSI system 4-Order in multi-pack part numbers

© SKF, Scotseal and TF are registered trademarks of the SKF Group.

© SKF Group 2018

The contents of this publication are the copyright of the publisher and may not be reproduced (even extracts) unless permission is granted. Every care has been taken to ensure the accuracy of the information contained in this publication but no liability can be accepted for any loss or damage whether direct, indirect or consequential arising out of the use of the information contained herein.

Publication 457644 • rev. 10/18 • Printed in U.S.A.

SKF VSM NA
890 N. State Street
Suite 200
Elgin, IL 60123
800-882-0008
www.vsm.skf.com